

## Gartenschuppen Typ 3

408 x 254 x 220 cm

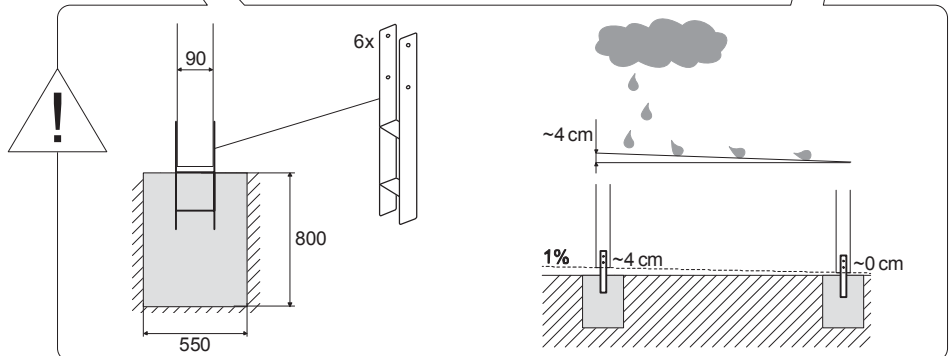
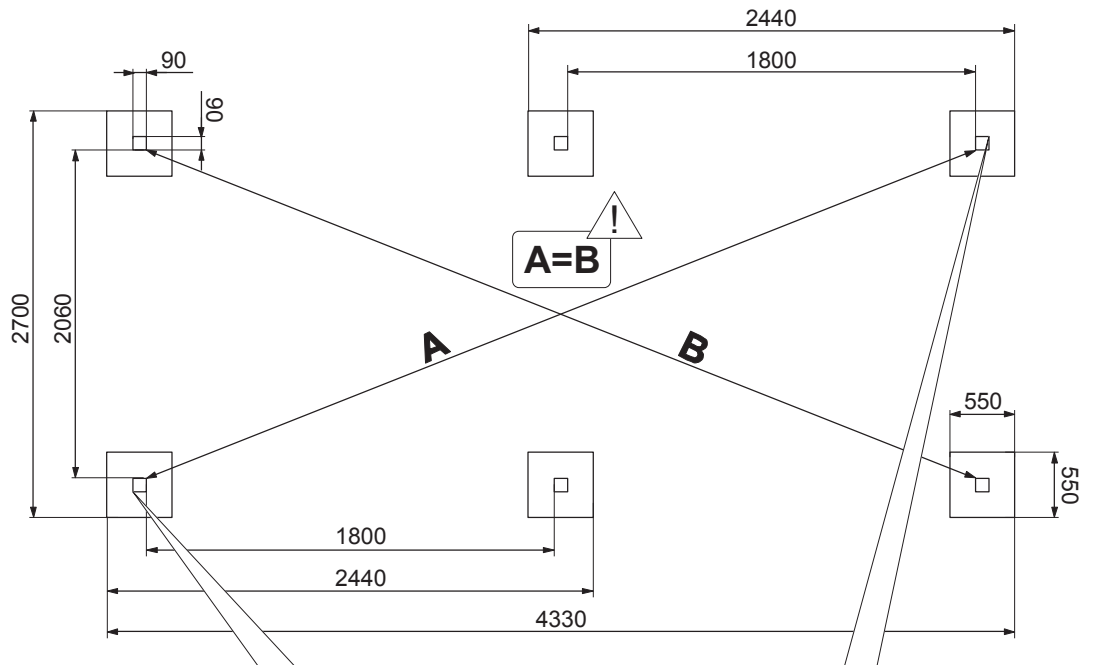
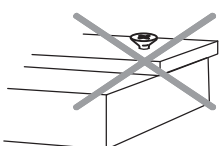
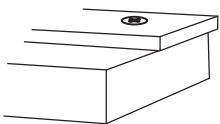
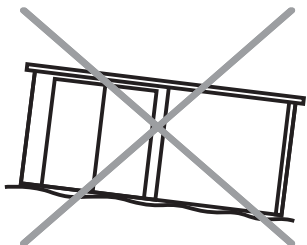
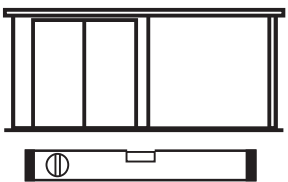

## **D** Allgemeine Informationen

Vor dem Aufbau ist der Bausatz auf Vollständigkeit und Richtigkeit zu kontrollieren. Bei einer Zwischenlagerung vor dem Aufbau darf das Holz nicht luftdicht verpackt oder in einem geschlossenen Raum ohne ausreichende Belüftung gelagert werden, da es durch natürliche Holzfeuchte schnell zu Schimmelbefall oder Stockflecken kommen kann.

Um das Vergrauen und die Rissbildung des Holzes zu minimieren empfehlen wir, das Holz mit einem Schutzanstrich (offenporige Lasur) zu versehen. Alle Maße sind ca.-Maße. Technische Änderungen vorbehalten. Grundsätzlich wird jede akzeptierte Reklamation nur mit der Zusendung von neuen Teilen erledigt und nicht finanziell abgegolten. Fehlerhafte Teile, die bereits verbaut oder gestrichen wurden, sind vom Umtausch ausgeschlossen. Es besteht kein Anspruch auf die Erstattung von weitergehenden Folgekosten wie z.B. Montage- oder Materialkosten (Farben usw.).

## **I** Informazioni generali

Prima del montaggio bisogna verificare la completezza e la conformità della scatola di montaggio. In caso di stoccaggio temporaneo prima del montaggio, il legno non deve essere confezionato ermeticamente né conservato in una stanza chiusa e senza sufficiente aerazione in quanto, a causa dell'umidità naturale del legno, si possono verificare rapidamente infestazioni di muffa o macchie dovute allo stoccaggio.

Per ridurre la possibilità di crepe o di ingrigimento del legno, consigliamo di provvedere con una vernice protettiva (verniciatura velata a poro aperto). Tutte le dimensioni sono approssimative. Ci riserviamo eventuali modifiche tecniche. Sostanzialmente ogni reclamo accolto viene risolto con la spedizione di pezzi nuovi, senza compensi finanziari. È escluso il cambio di pezzi difettosi già rovinati o verniciati. Non si ha alcun diritto al rimborso di spese successive, ad es. per il montaggio o per il materiale (colori, ecc.)

## **E** Encontrará información

Antes de proceder a su montaje, asegúrese de que el juego se encuentre en perfecto estado y no tenga piezas defectuosas. Si va a almacenar temporalmente la madera antes de su montaje, evite envolverla herméticamente o depositarla en un espacio cerrado sin suficiente ventilación, pues la humedad de la madera natural puede transformarse rápidamente en una plaga de hongos o manchas de moho.

A fin de minimizar el envejecimiento y la formación de grietas en la madera recomendamos revestirla con una capa de pintura protectora (barniz poroso). Todas las medidas son referencias aproximadas. Sujeto a posibles modificaciones técnicas. En principio, las reclamaciones aceptadas únicamente serán compensadas mediante el envío de piezas nuevas, no habrá compensación económica. Las piezas defectuosas que ya hayan sido montadas o pintadas quedan excluidas de cualquier cambio. Queda excluido el derecho al reembolso de los costes adicionales originados posteriormente, como por ejemplo los costes de montaje o de material (pinturas, etc.).

## **F** Retrouvez les informations

Verifiez avant le montage que le kit est complet et conforme. En cas de stockage provisoire avant le montage, le bois ne doit pas être emballé sous vide ou stocké dans une pièce fermée, sans une aération suffisante, car cela peut rapidement faire apparaître de nombreuses tâches de moisissure en raison de l'humidité naturelle du bois.

Afin d'éviter que le bois ne grise et ne se fissure, nous recommandons de le recouvrir d'un enduit de protection (lasure poreuse). Toutes les mesures sont approximatives. Sous réserve de modifications techniques. En principe, chaque réclamation acceptée n'est réglée qu'avec l'envoi de nouvelles pièces et n'est pas indemnisée financièrement. Des éléments défectueux qui ont déjà été montés ou peints ne peuvent pas être changés. Il n'existe aucun droit au remboursement des frais ultérieurs supplémentaires tels que les frais de montage ou de matériaux (peinture, etc.).

## **GB** General information

Check that the construction set is complete and correct before beginning assembly. If stored before assembly, the wood should not be kept in airtight packaging or stored in a sealed room without sufficient ventilation, since the natural moisture in the wood can lead to mould or staining.

To minimise greying or cracking in the wood, we recommend using a protective varnish (open-pore glaze). All measurements given are approximate. In general, complaints are rectified by the provision of new parts, rather than financial remuneration. Faulty parts which have already been assembled or varnished cannot be exchanged. There is no claim to remuneration for any further follow-up costs, such as assembly or material costs (paints etc.).

## **NL** Algemene informatie

Vóór de opbouw dient gecontroleerd te worden of de bouwset compleet en juist is. Bij een tussenopslag vóór de opbouw mag het hout niet luchtdicht verpakt of in een gesloten ruimte zonder voldoende ventilatie opgeslagen worden, aangezien er door natuurlijke houtvochtigheid snel schimmelaantasting of vochtvlekken kunnen ontstaan.

Om het vergrauen en de scheurvorming van het hout tot een minimum te beperken, raden wij aan het hout te voorzien van een beschermlaag (beitsing met open poriën). Alle maten zijn worden bij benadering gegeven. Technische wijzigingen voorbehouden. In principe wordt iedere geaccepteerde claim alleen afgehandeld met de toezending van nieuwe onderdelen en niet financieel vereffend. Defecte onderdelen, die reeds gemonteerd of geverfd zijn, zijn uitgesloten van de omwisseling. Er kan geen aanspraak worden gemaakt op de vergoeding van verdergaande vervolgcosten zoals bv. montage- of materiaalkosten (verven enz.).

- 34x (A) - 5 x 140
- 32x (B) - 4 x 60
- 312x (C) - 3,5 x 35
- 810x (D) - 3 x 25
- 17x (E) - 4 x 16

- 4x (F) - M8 x 100
- 2x (G) - M8 x 140

- 6x (H) - M8

- 6x (I) - Ø8

- 119x (J) - 4,8 x 25

- 37x (K) - 30 x 30

- 1x (L) - 150 x 150 x 55

- 1x (M)

- 1x (N)

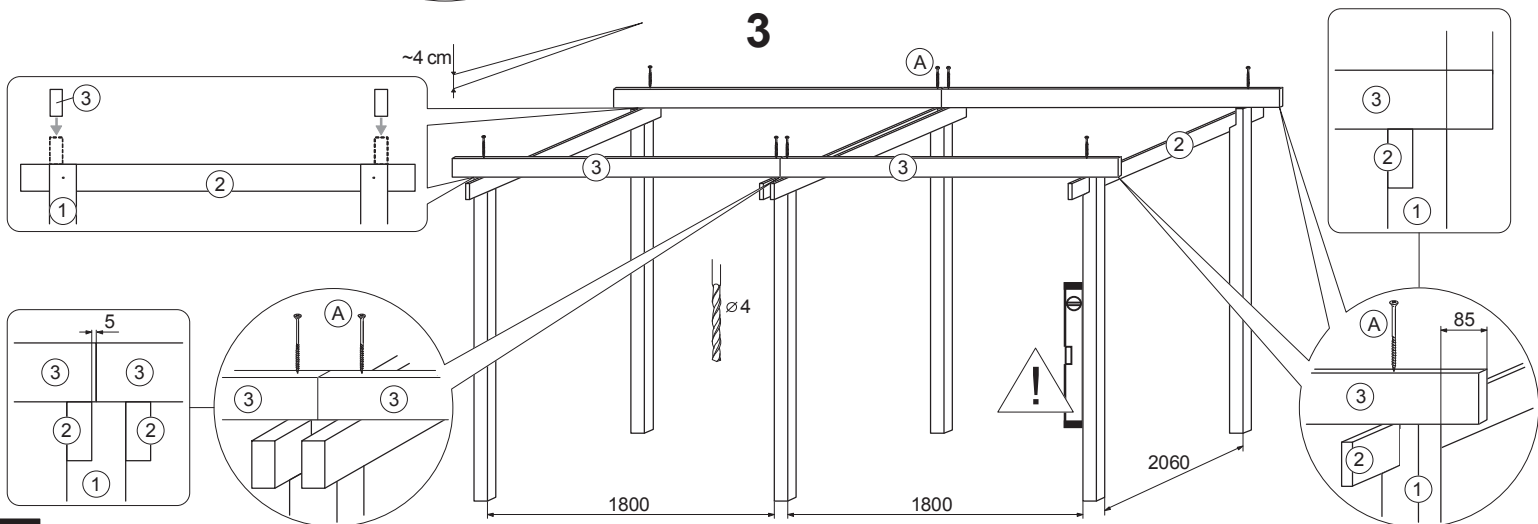
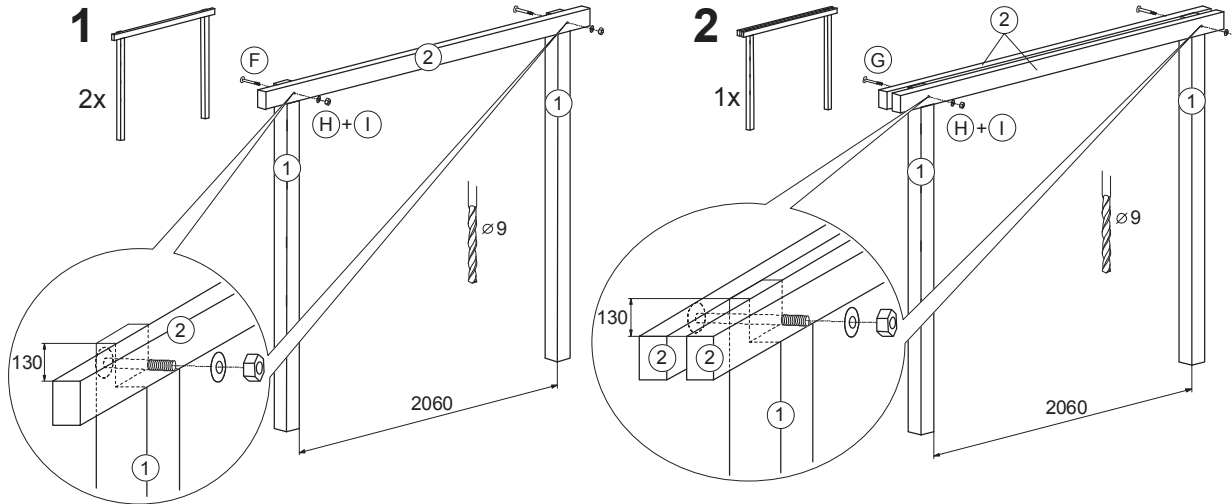
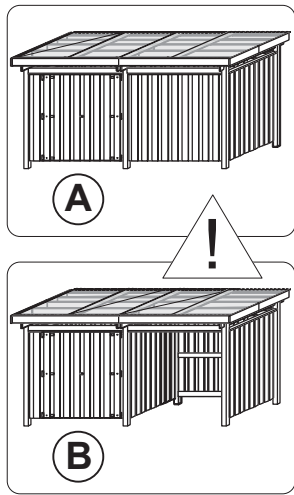
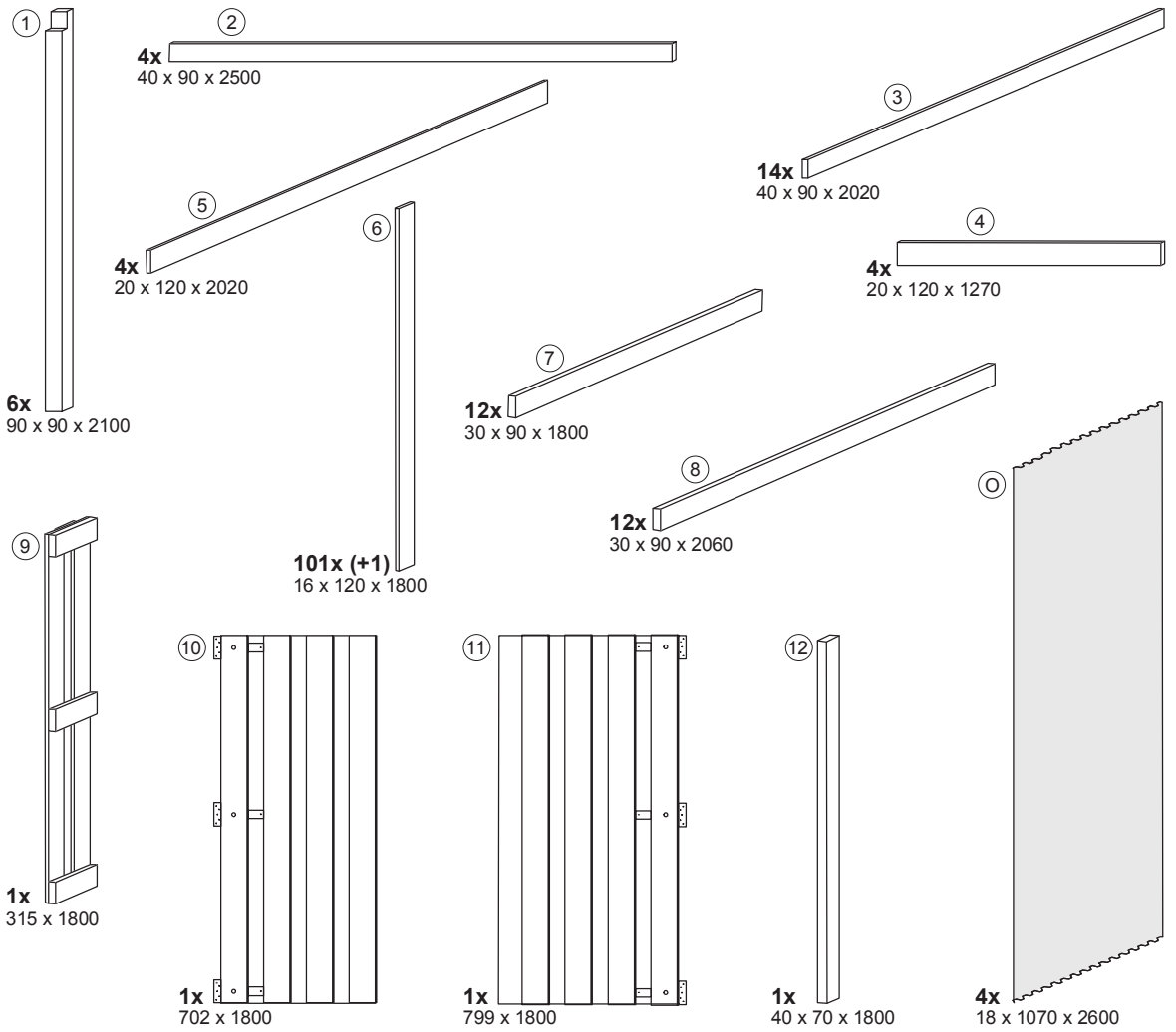

4

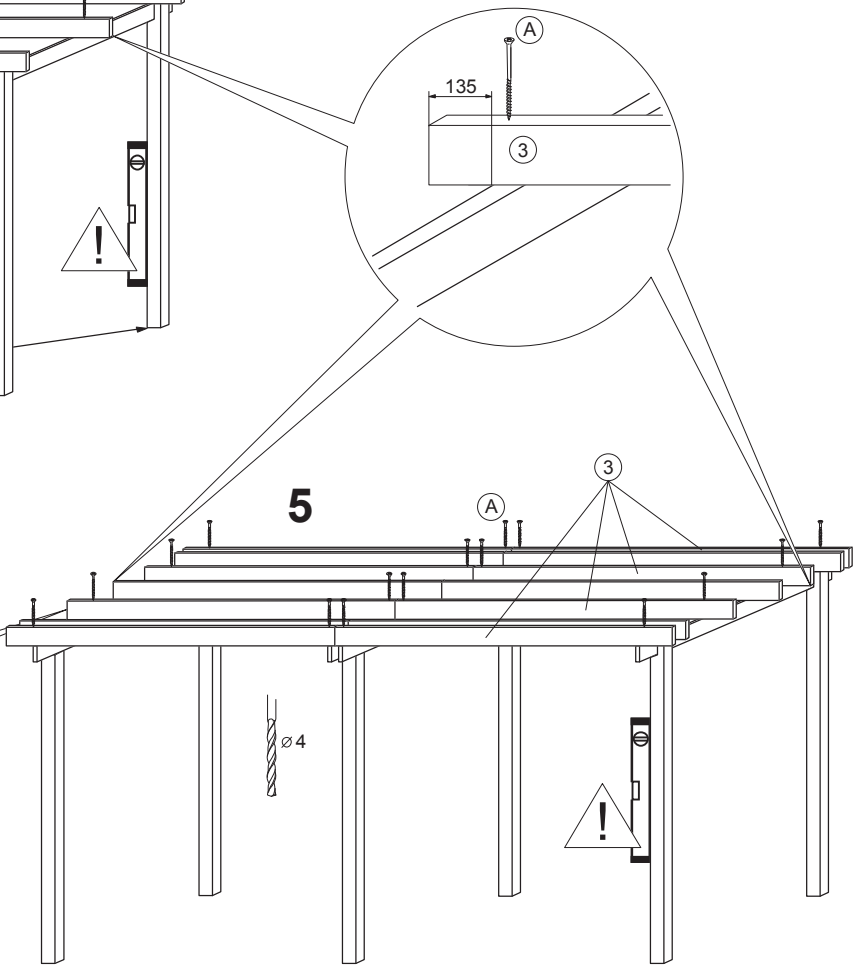
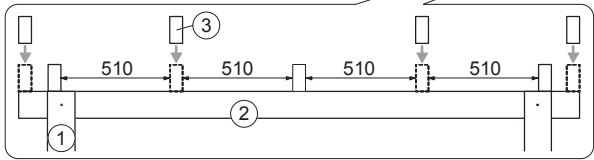
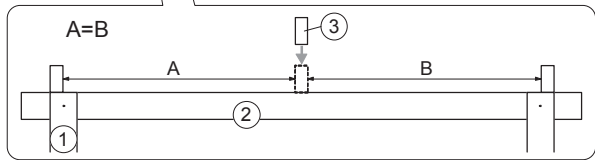
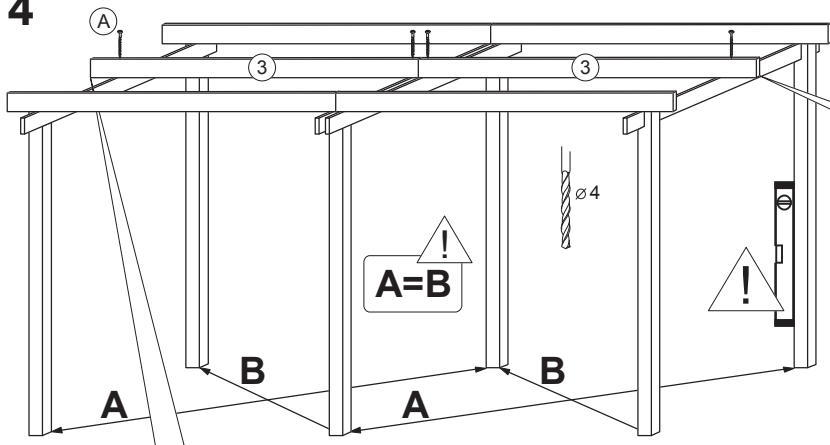

6

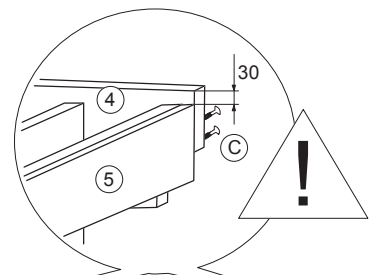
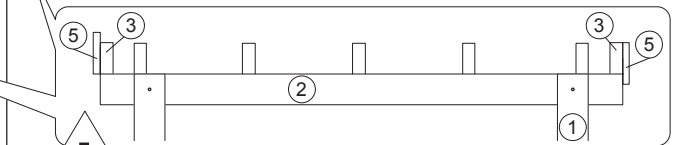
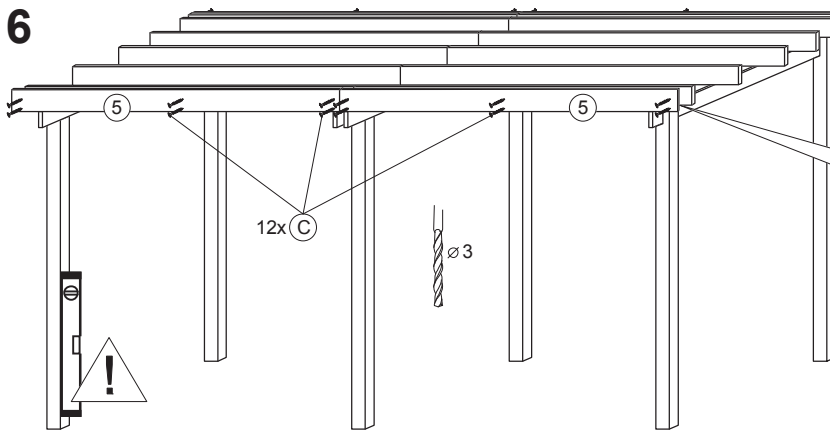

7

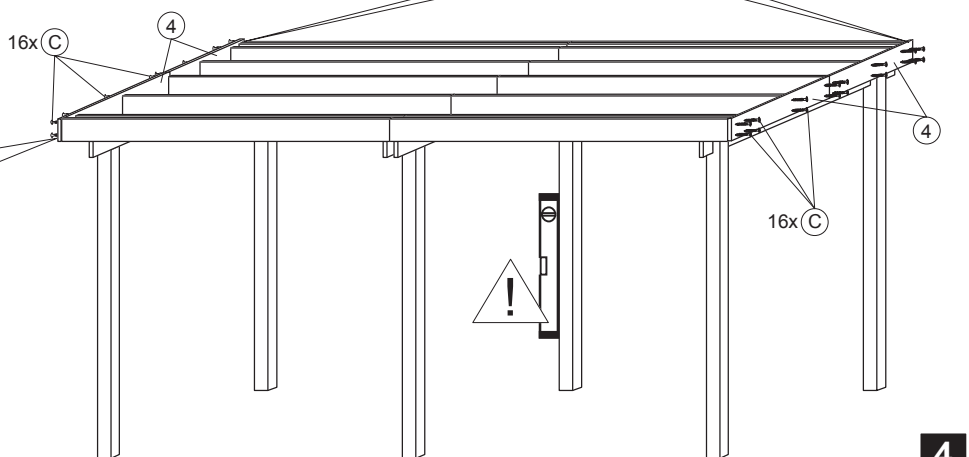
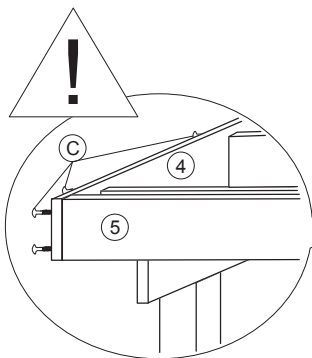

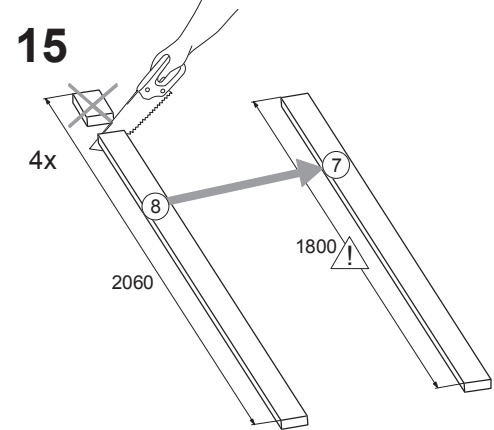
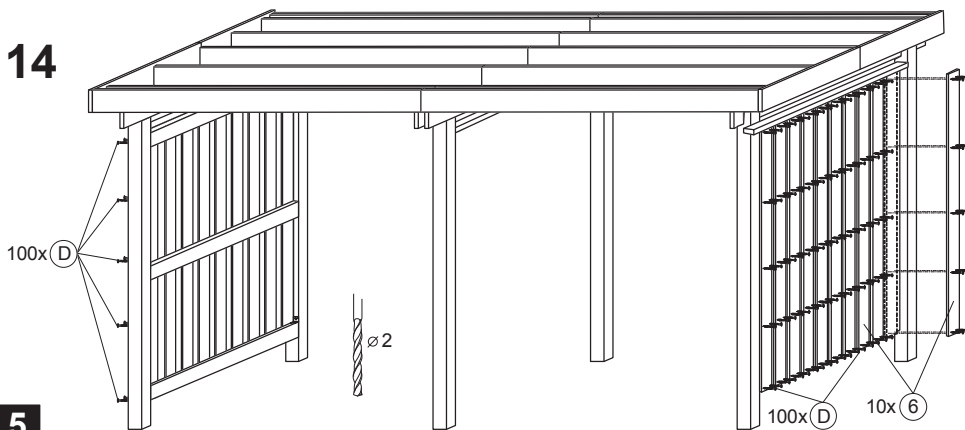
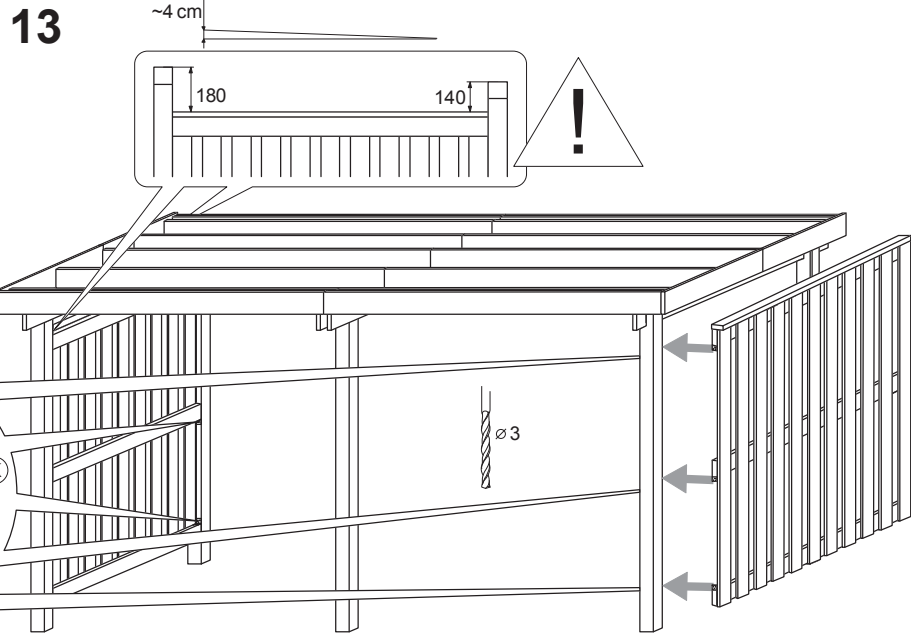
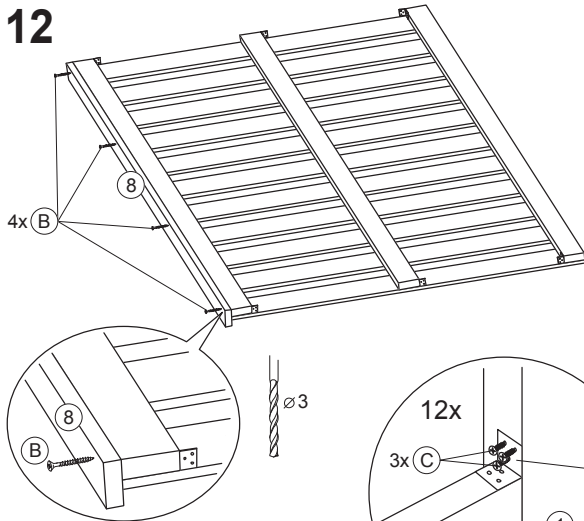
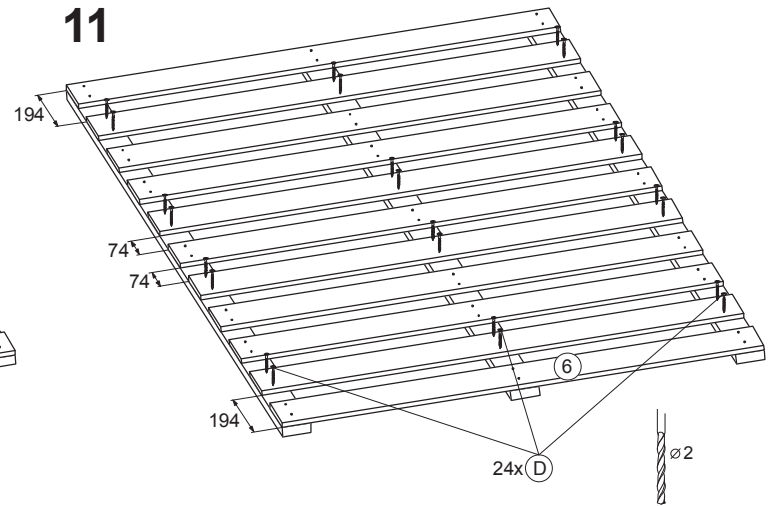
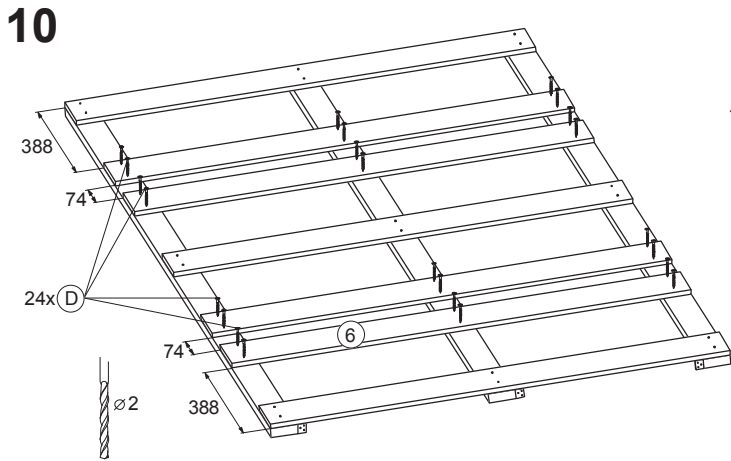
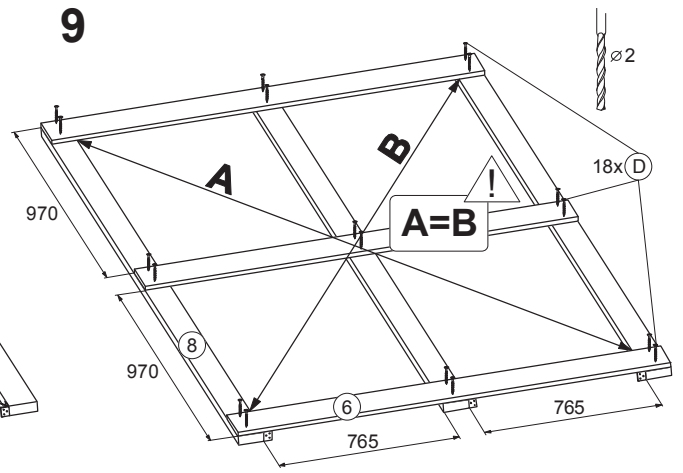
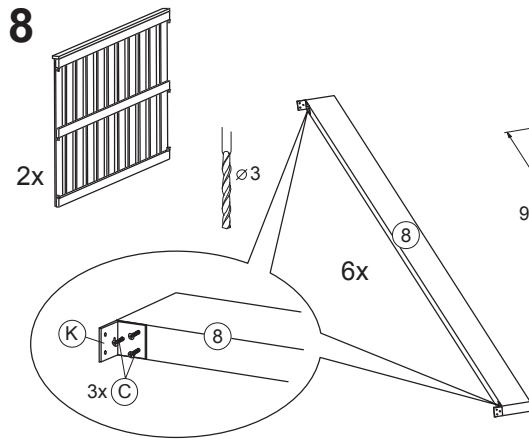
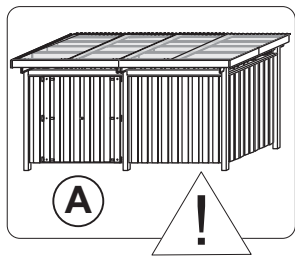

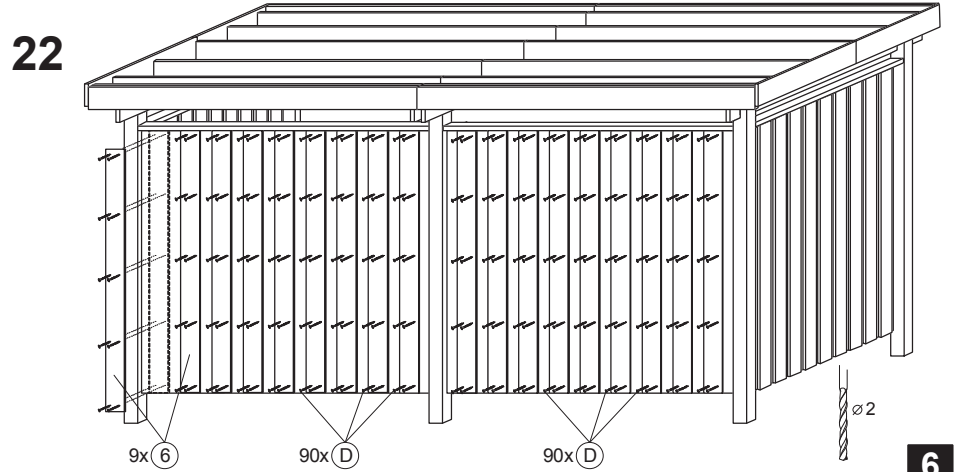
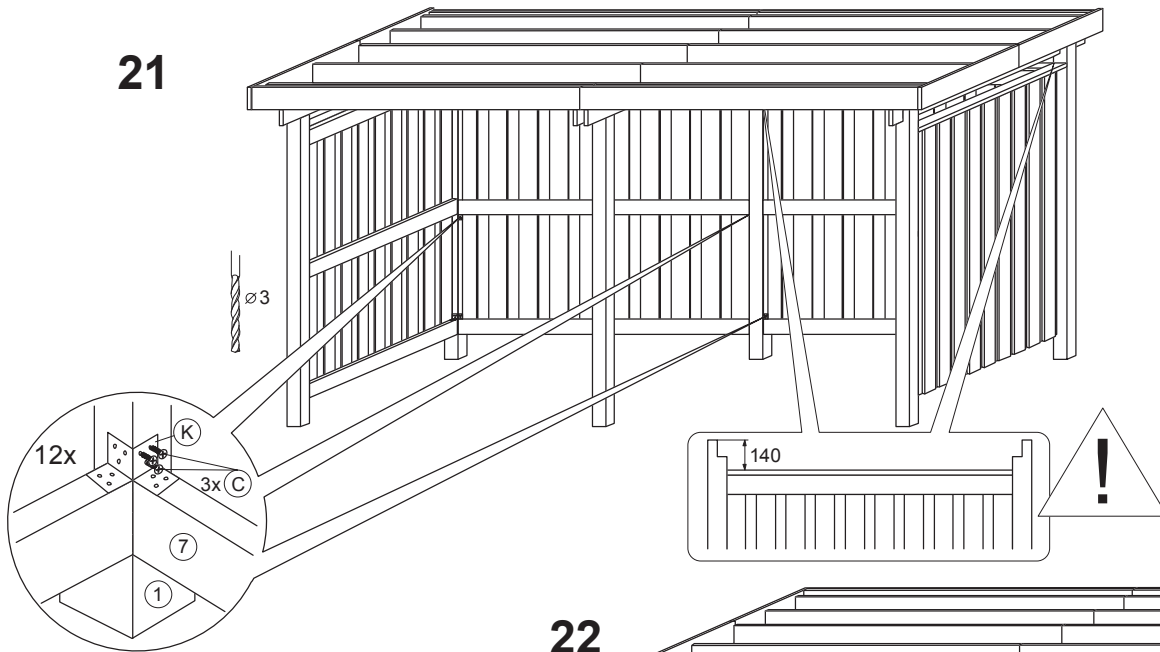
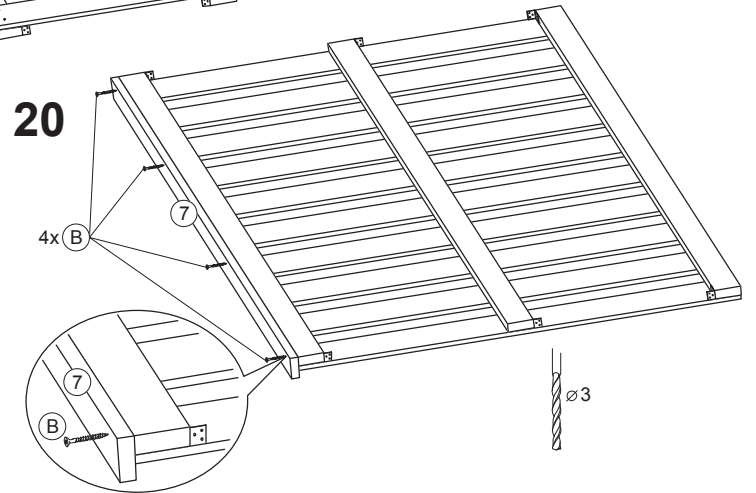
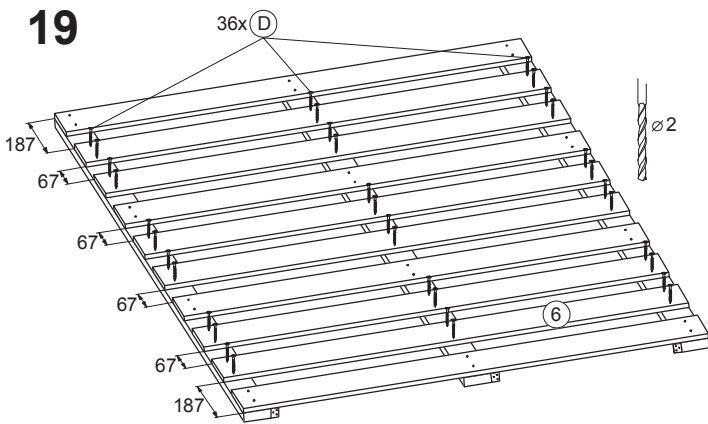
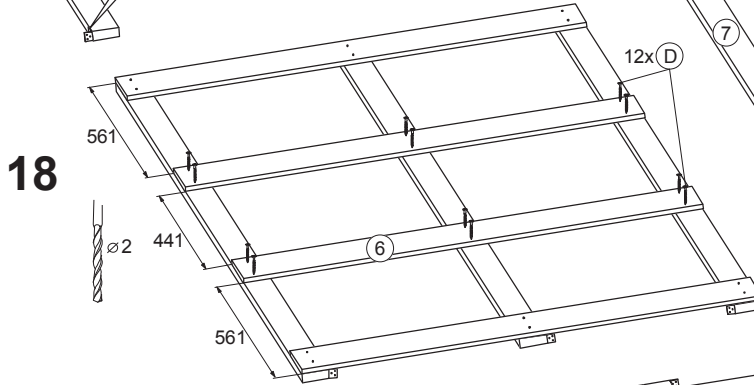
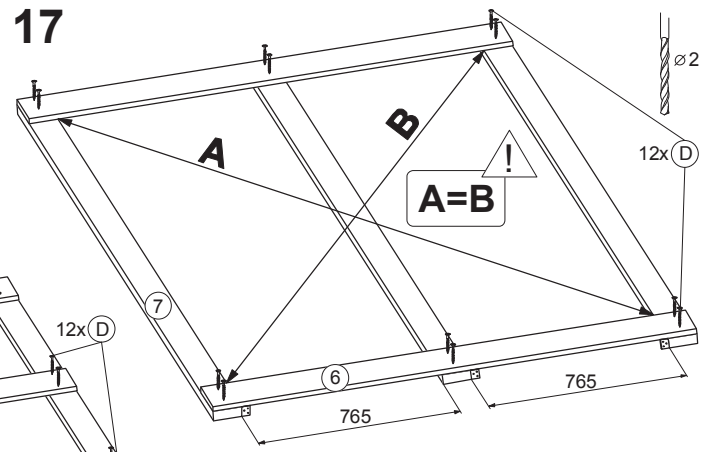
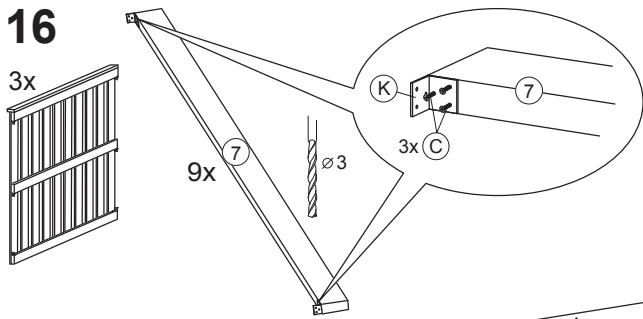

23

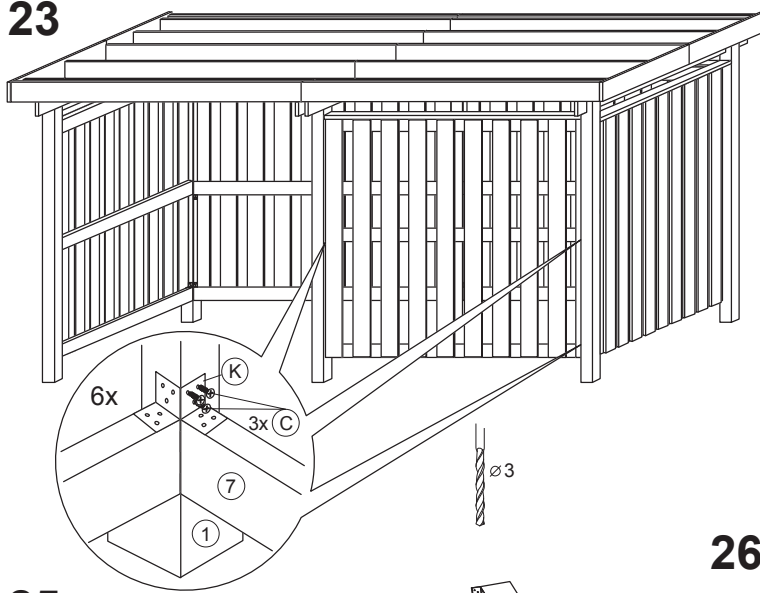

24

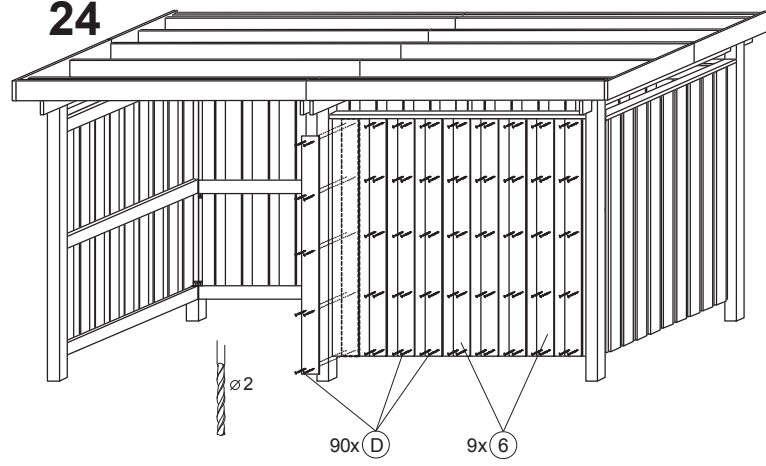

25

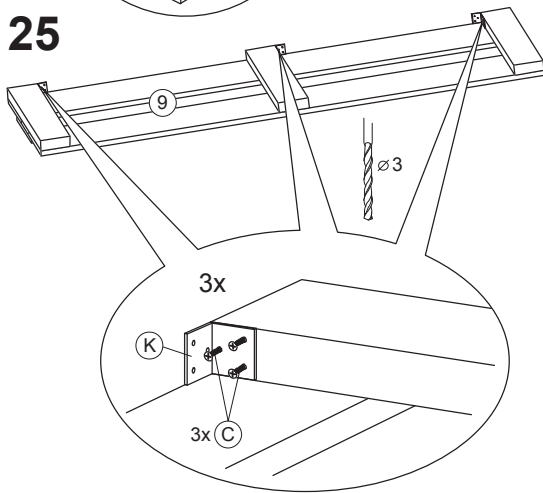

26

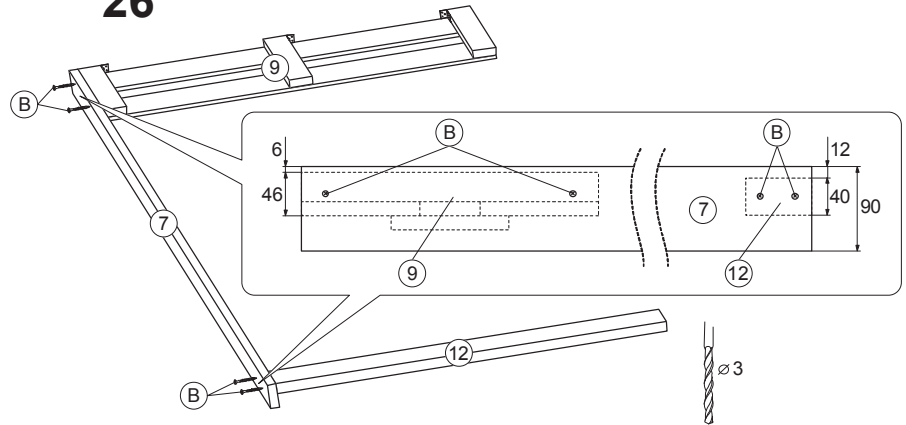

27

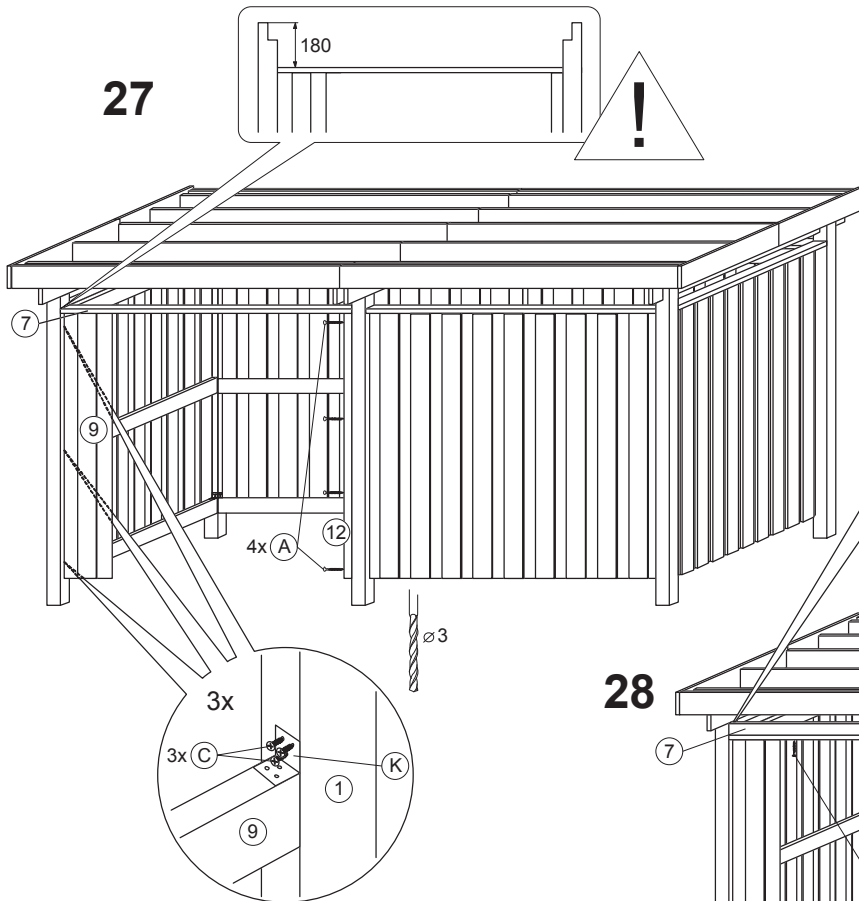

28

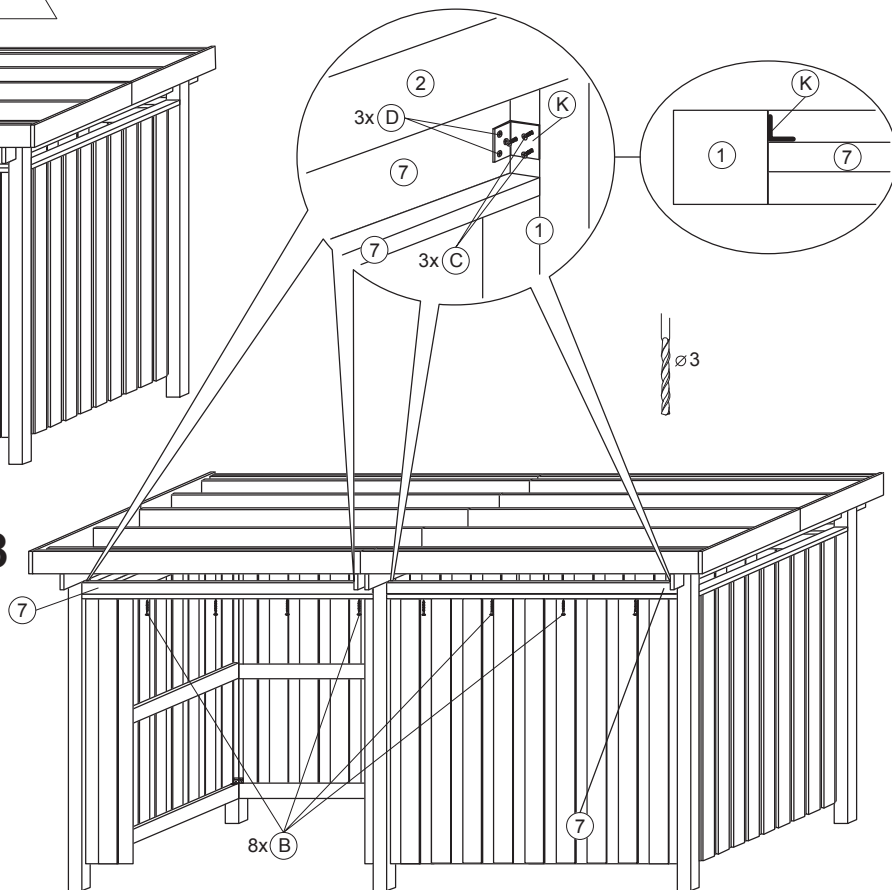



29

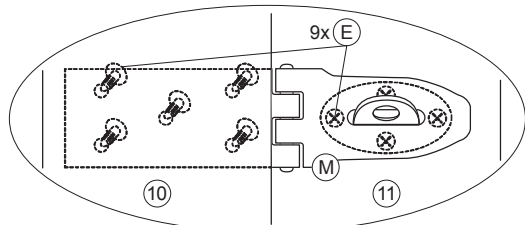
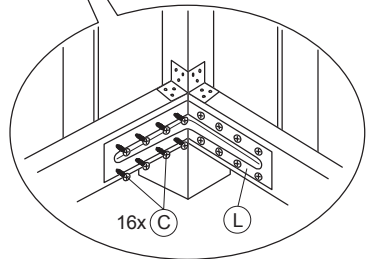
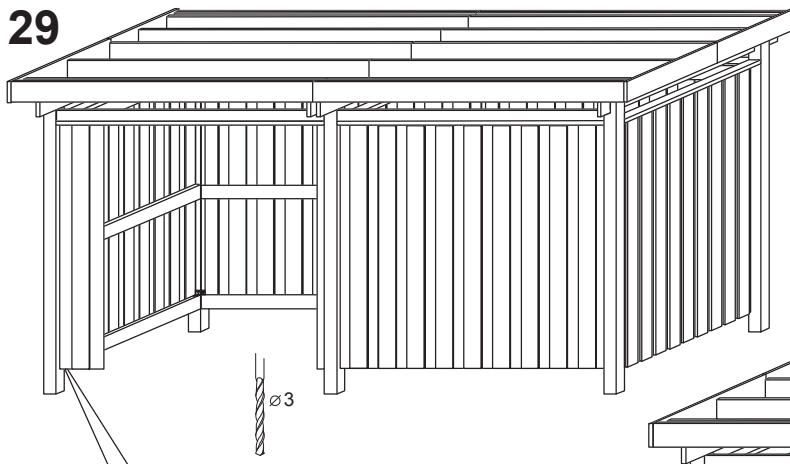

30

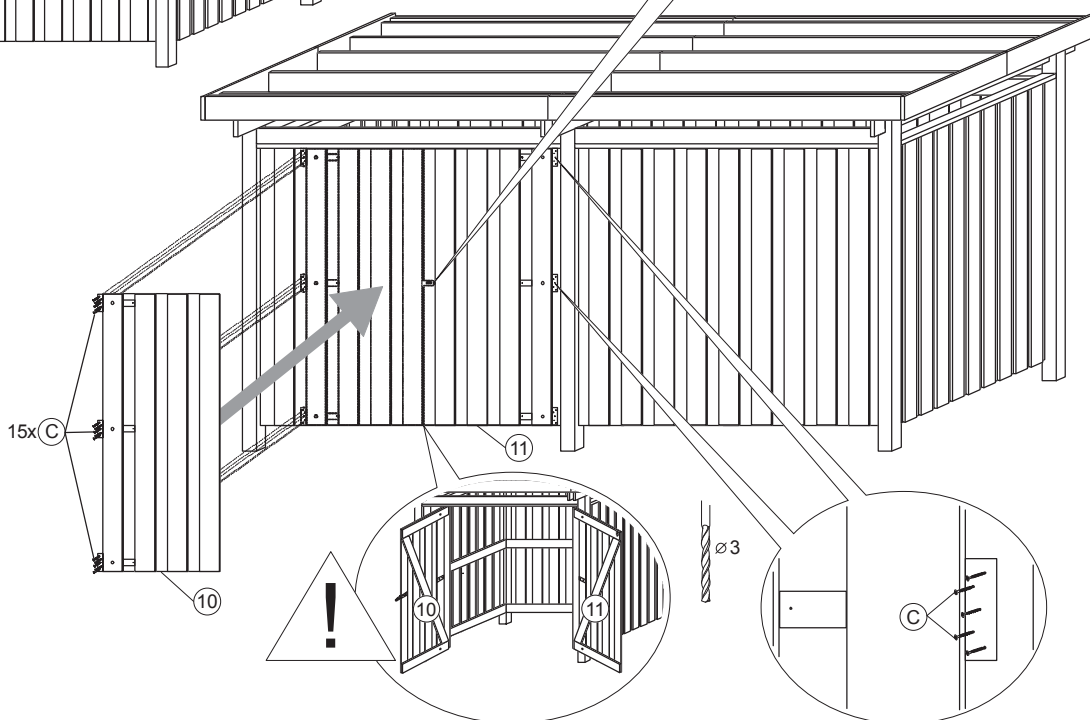

31

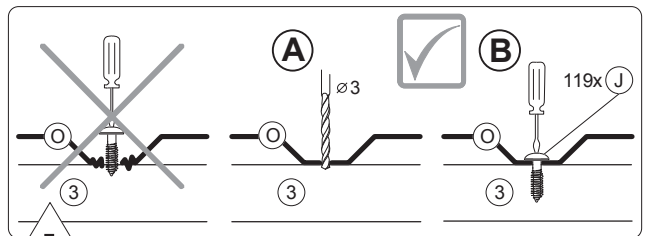
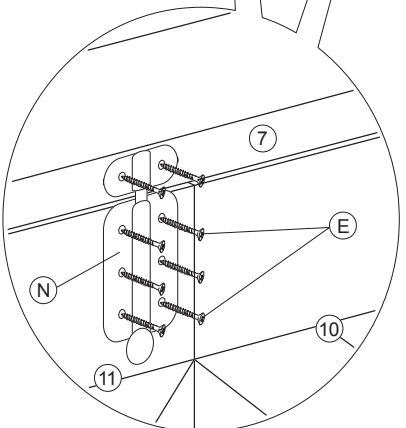
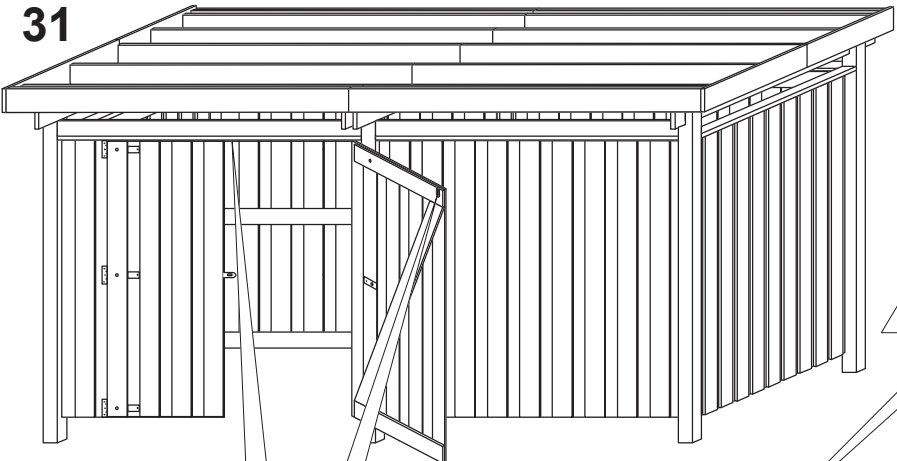

32

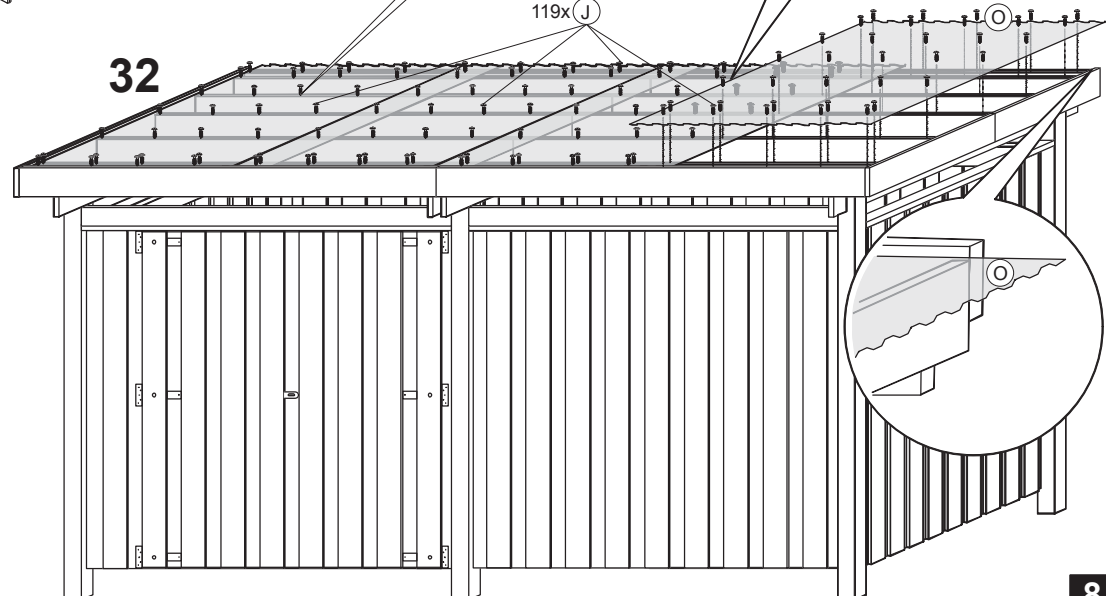



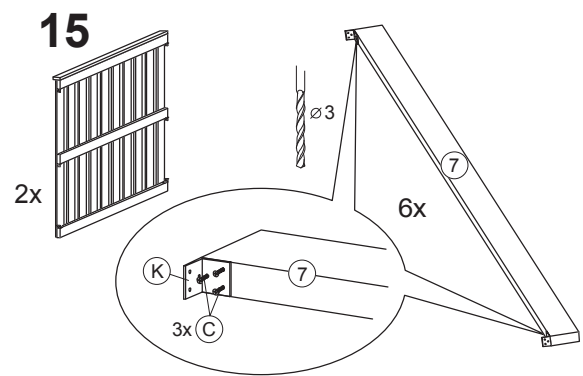
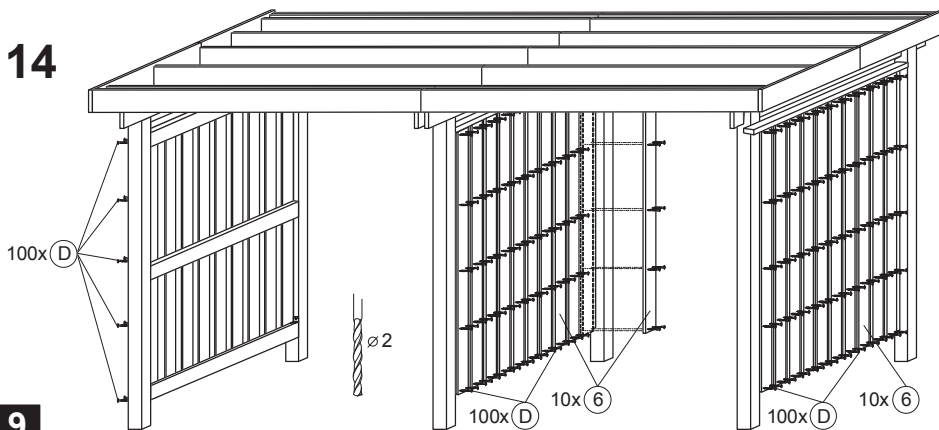
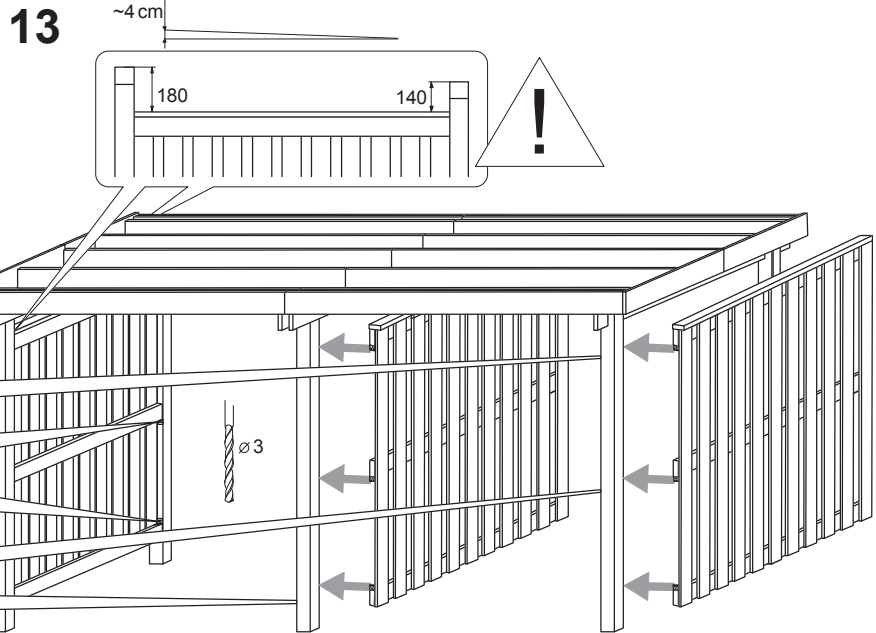
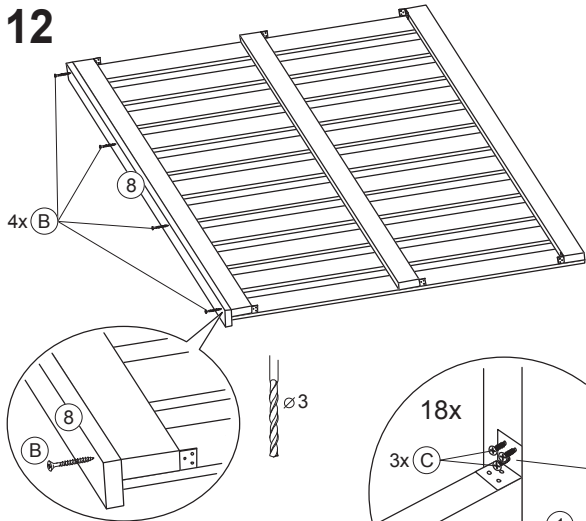
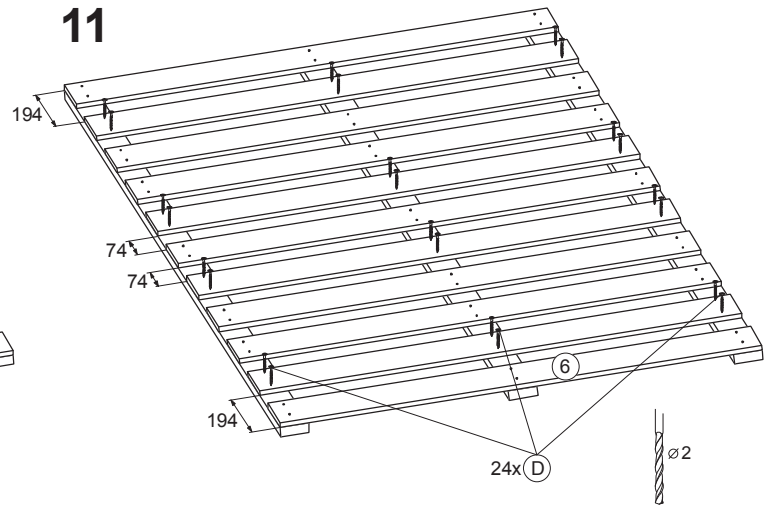
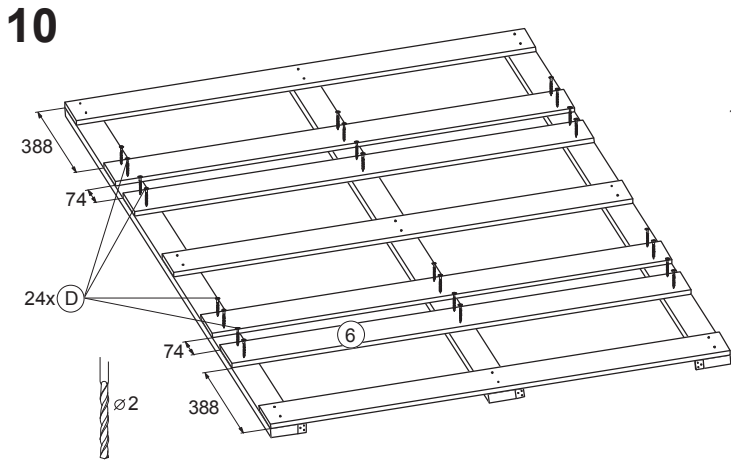
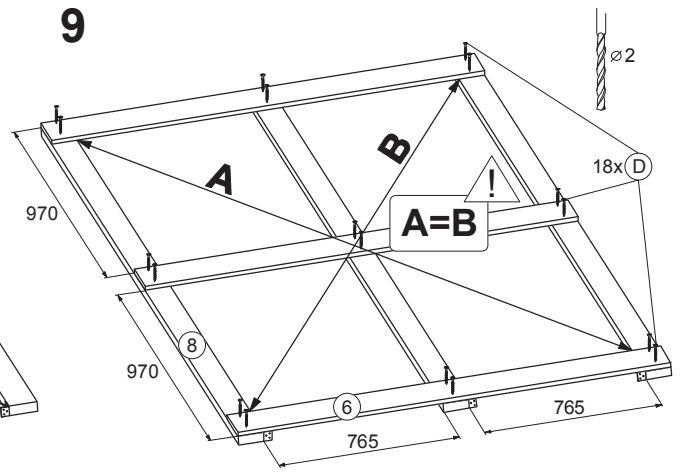
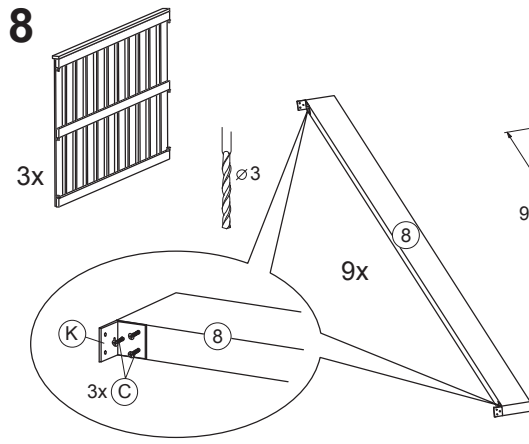
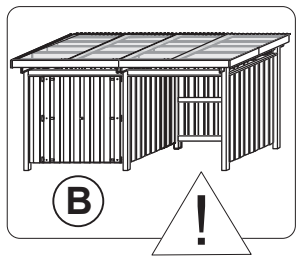

16

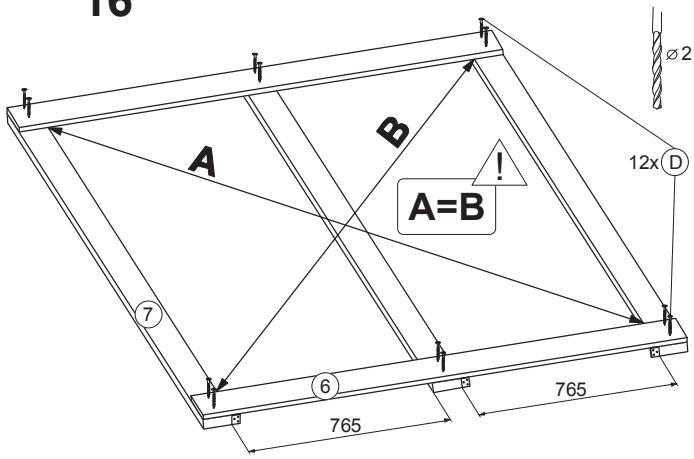

17

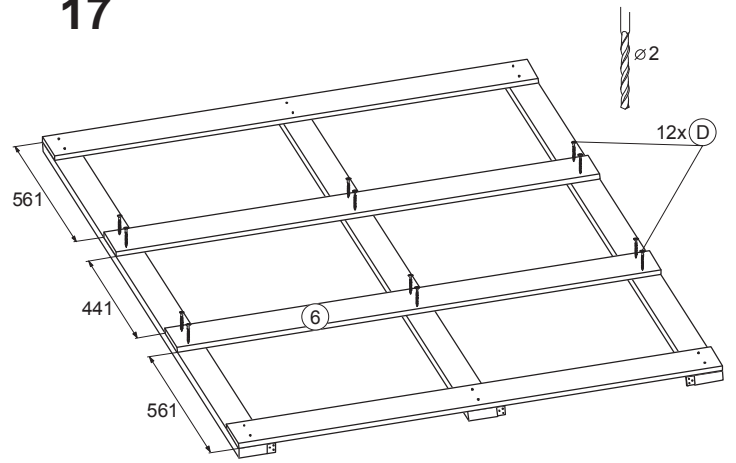

18

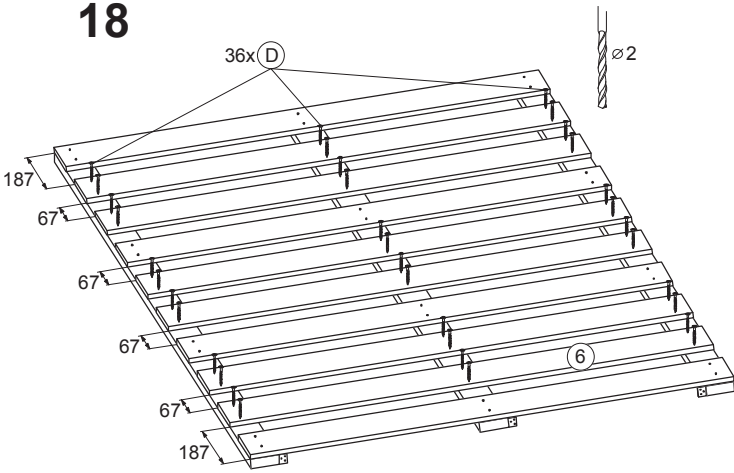

19

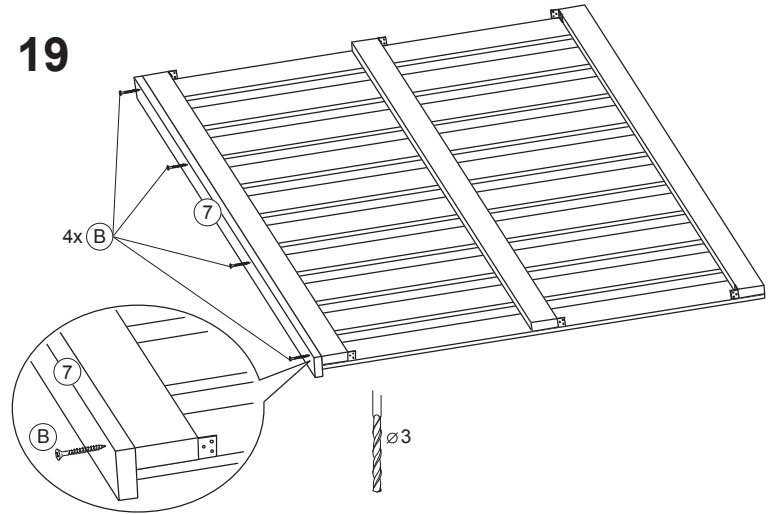

20

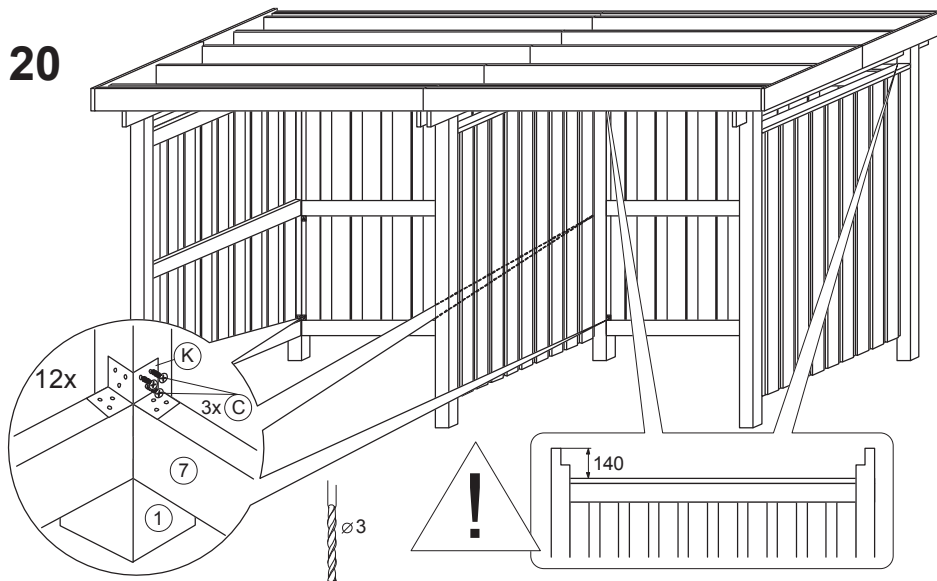

21

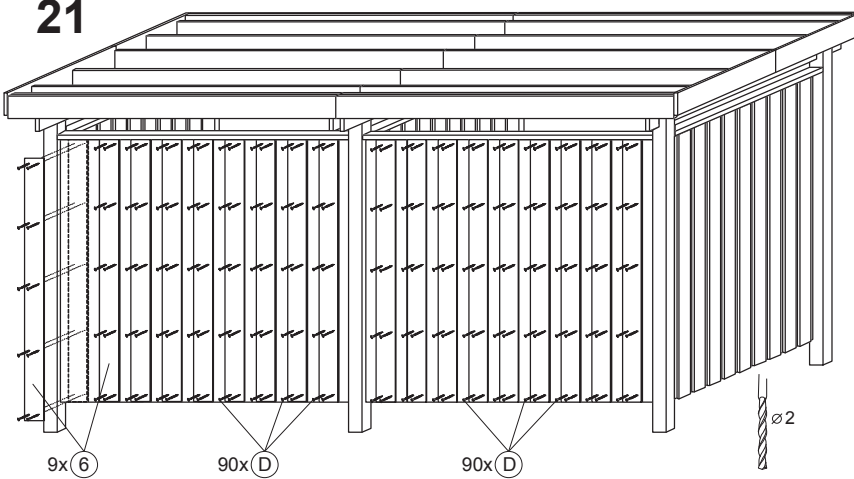

22

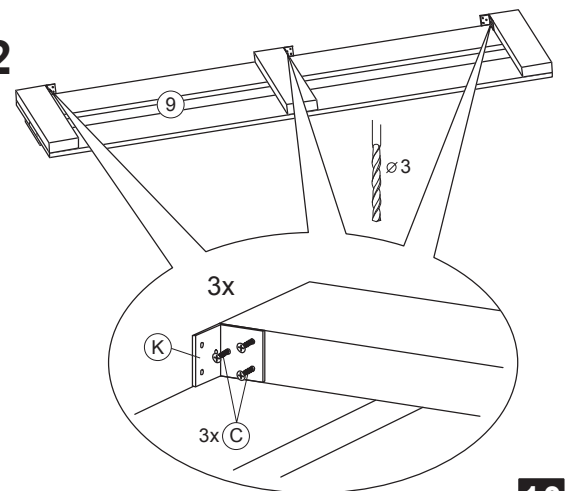

23

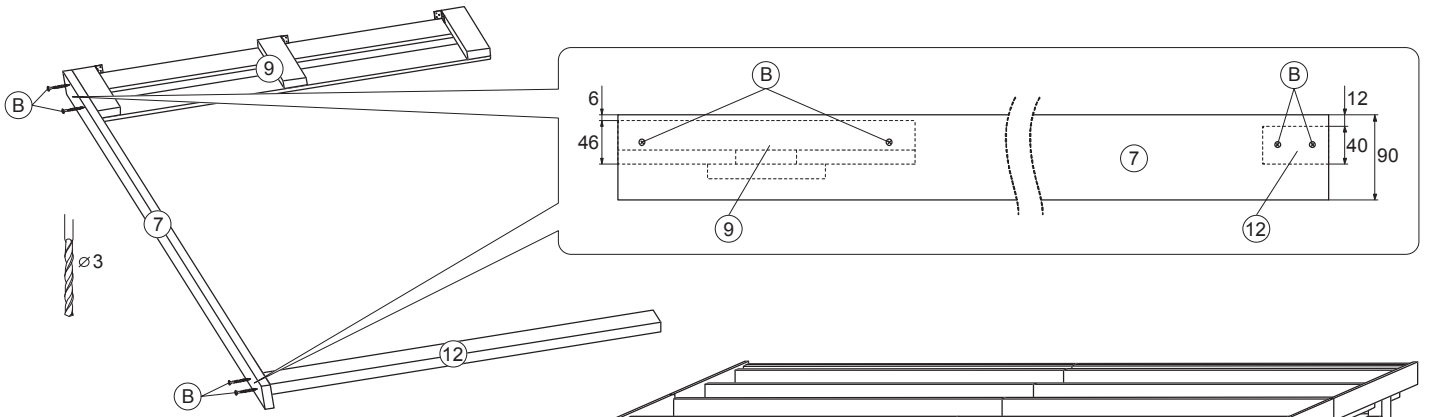

24

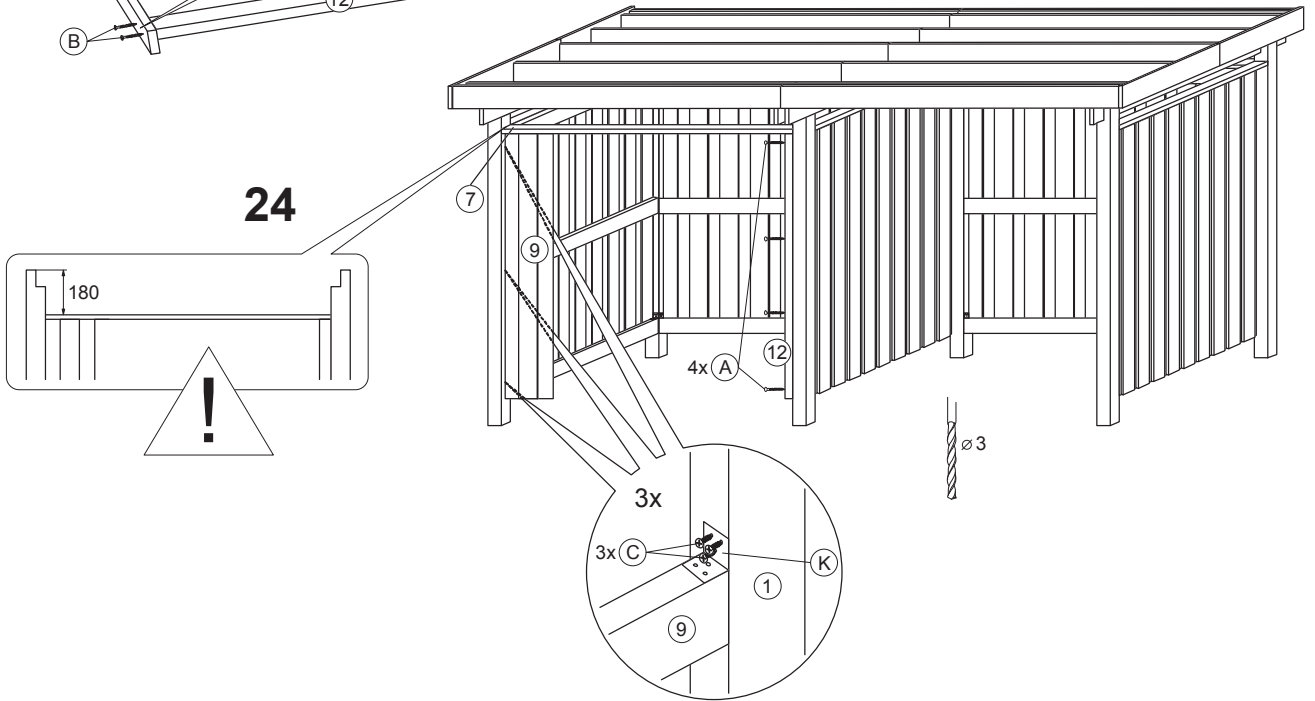

25

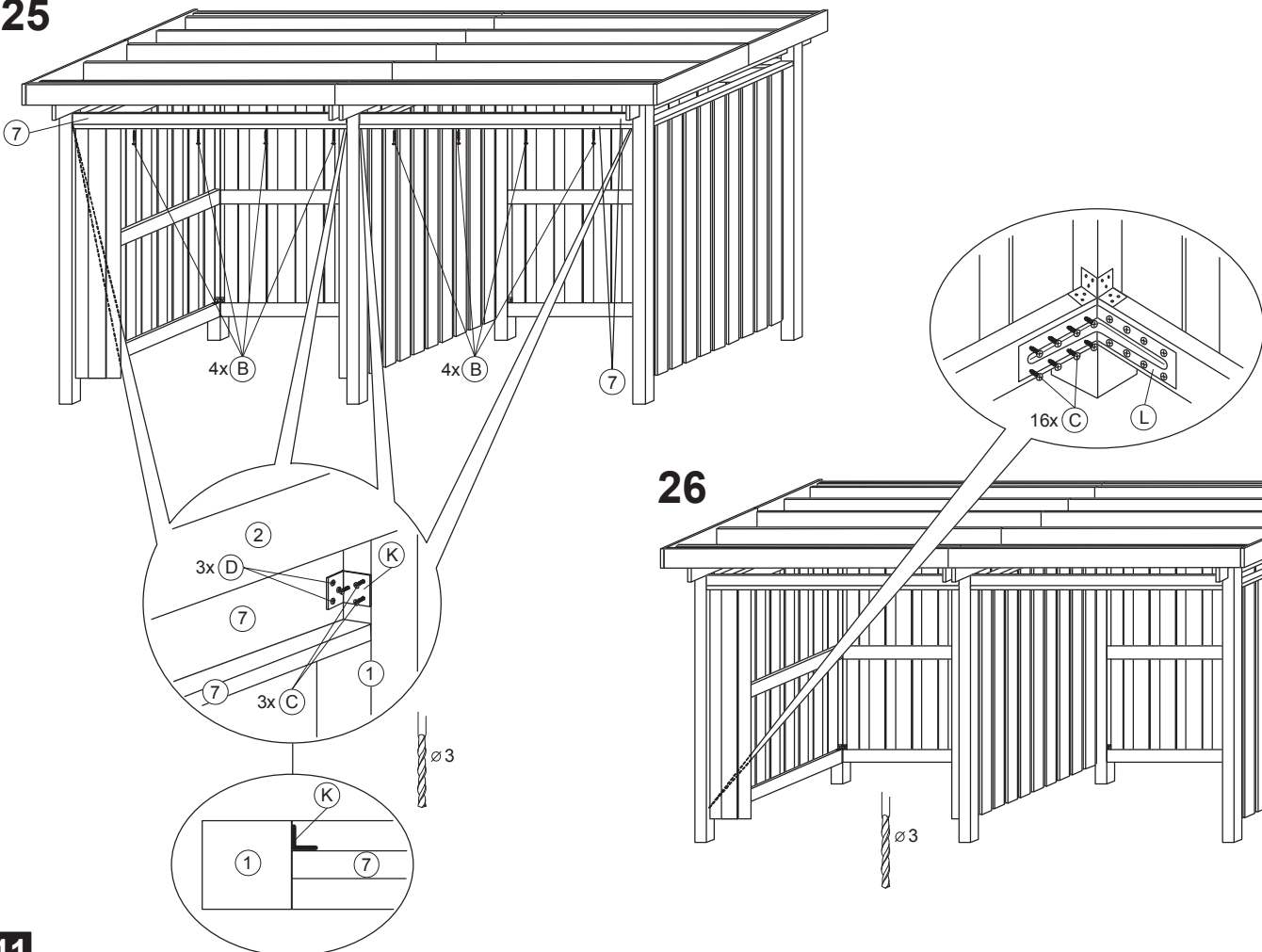

26

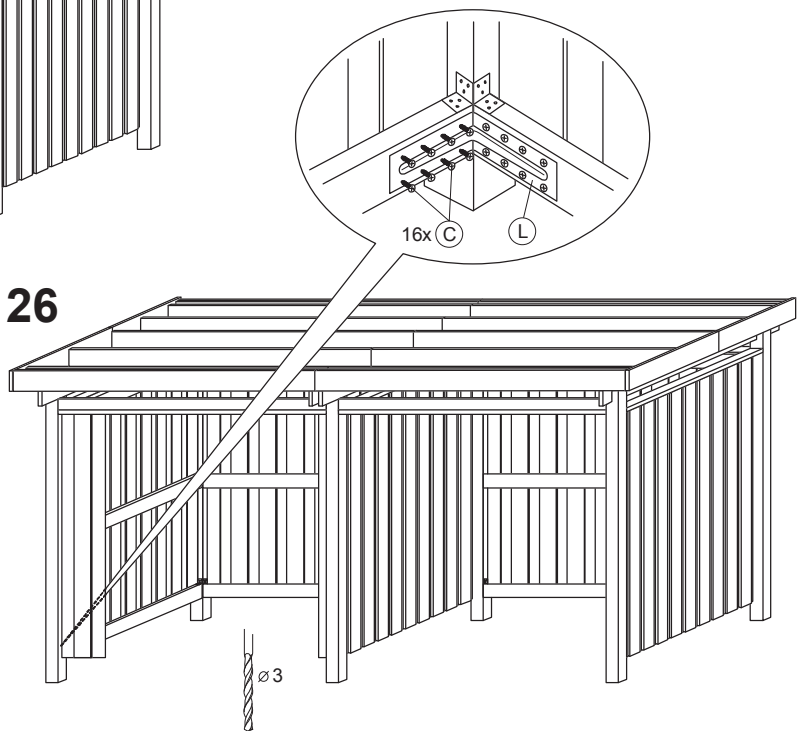

27

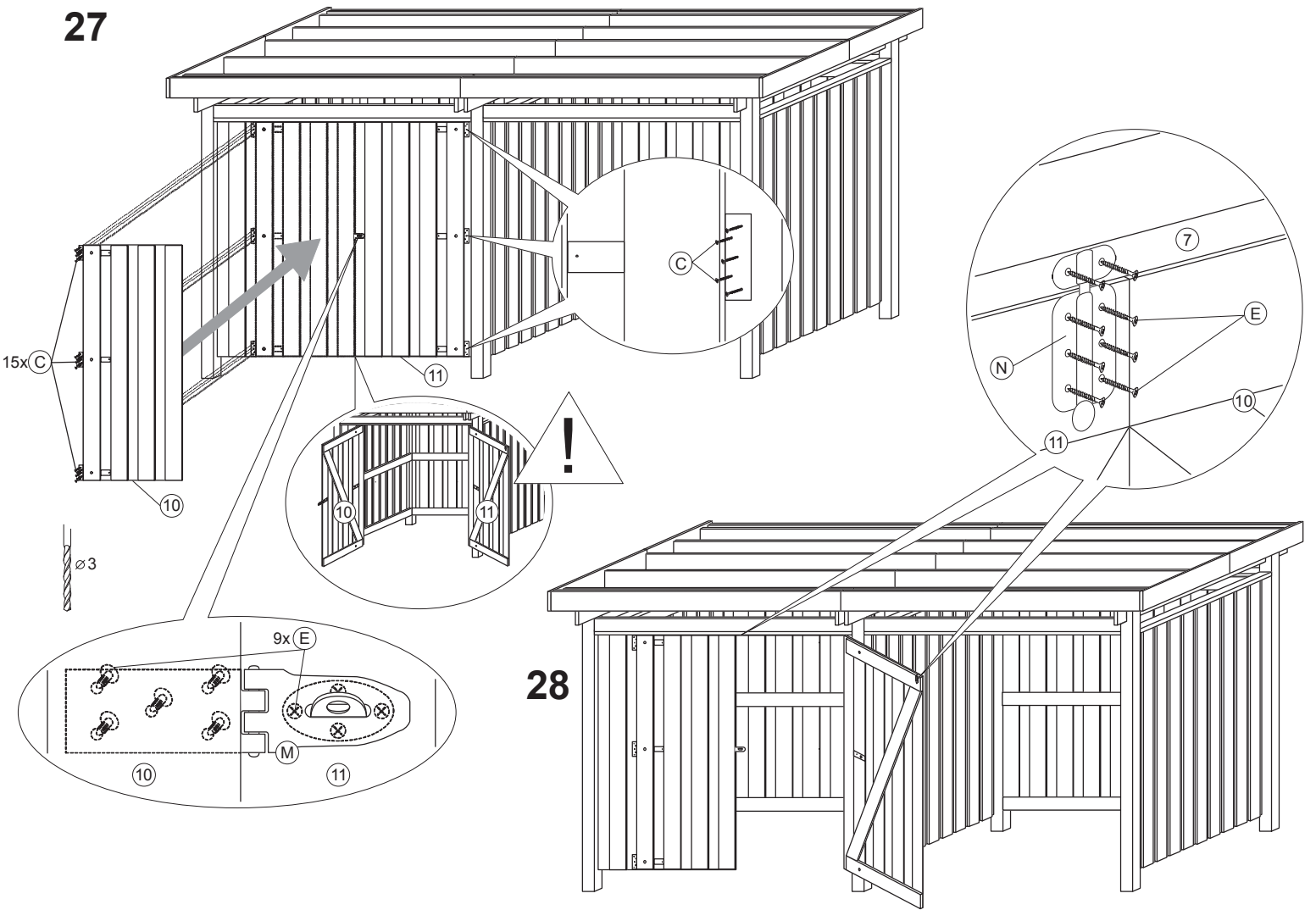

28

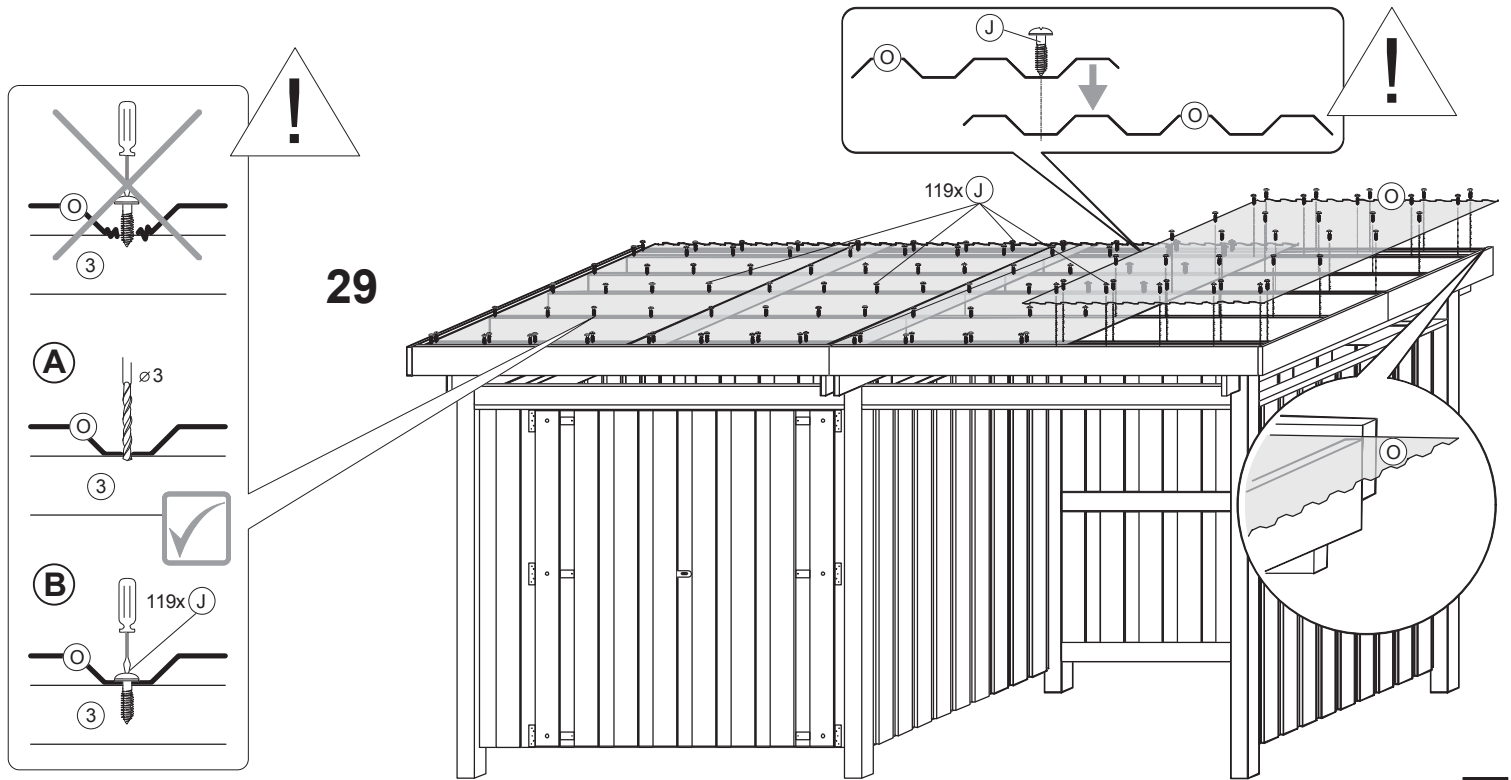

12